

**New !!**

# Aquatech

## RE-V100

### Dedicated programmable motor controller for RV-001 series Pinch valve



#### Features

- Dedicated motor controller for RV-001 series pinch valve.
- Up to three valves can be connected and each valve can be programmed to open and close at separate times.
- Connect to a Windows PC and input the operating program.
- The created operation program can be stored in the controller itself, therefore it can be operated without PC.
- The created operation programs can be saved on your PC and reused.
- The valve and controller are connected with a connector. To use the controller, a valve with connector is required.

#### Connection

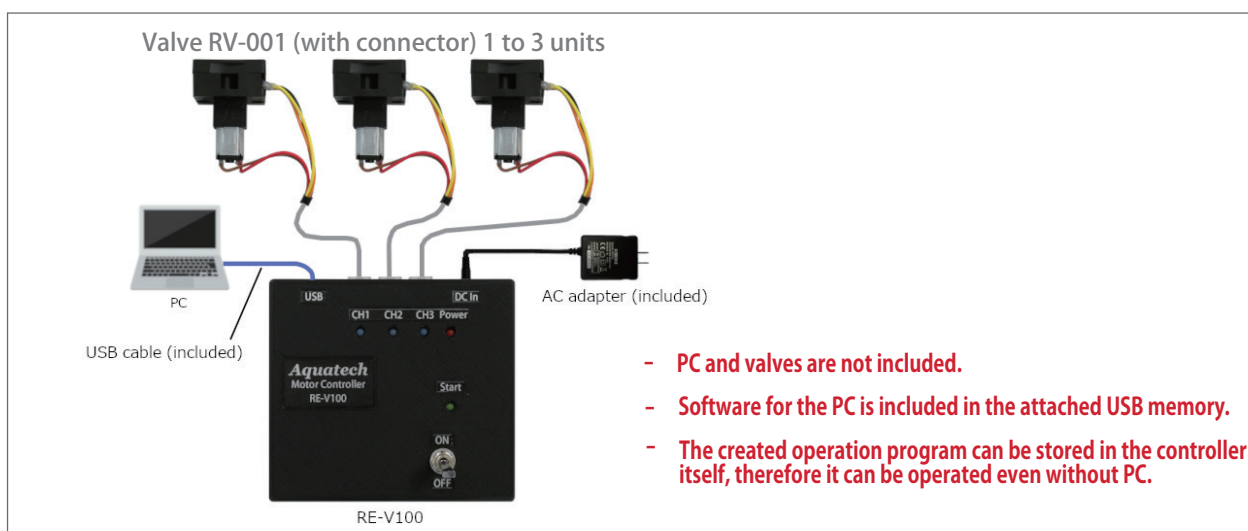

#### Main specifications

Commodity	Dedicated motor controller for RV-001 pinch valve
Model No.	RE-V100
Applicable model	RV-001 series (strictly with connector)
Connection to valve	Connection by connector
Power source	DC 5V 1A ( AC adapter included )
Dimensions ( W x D x H )	100 x 93 x 49 mm
Accessories	AC adapter (Input : AC100-240V 50/60Hz Output: DC5V 1A) USB memory stick (PC software), USB cable (for PC connection)

#### Explanation of indications



- ① USB connection terminal (USB A - micro B ; bundled)
- ② Valve connection terminals (Ch. ① - ③ )
- ③ DC - In connection terminal (AC - DC adaptor ; bundled)
- ④ Valve Indicator - Ch.① - ③ (LED turns blue when open)
- ⑤ Power - LED (Red)
- ⑥ Start Indicator - LED (Green)
- ⑦ Start switch - On / Off