

New !!

Ring Pump[®]

“Fixed Flow Rate” Pump System

RE-C300-MC Series



Features

- This is a metering pump system that combines an Aquatech’s ring pump using an encoder-equipped DC motor and its dedicated motor controller “RE-C300” to achieve metering by stopping the motor rotation at an exact integer multiple of one rotation.
- You can select tubing from 3 kinds of materials.

Main specifications

Flow rate	Max. 25mL / 1 mL - Step
Tubing	Silicone / PharMed BPT Transmaster TM-15
Motor/Power source	Encoder-equipped DC motor /24V
Weight (for reference)	Approx. 355g

The maximum flow rate is the volume for one operation that can be set on the RE-C300.

Examples of application

Analytical instruments, medical devices, cell culturing experiments and many other usage where micro-fluidic control is needed.

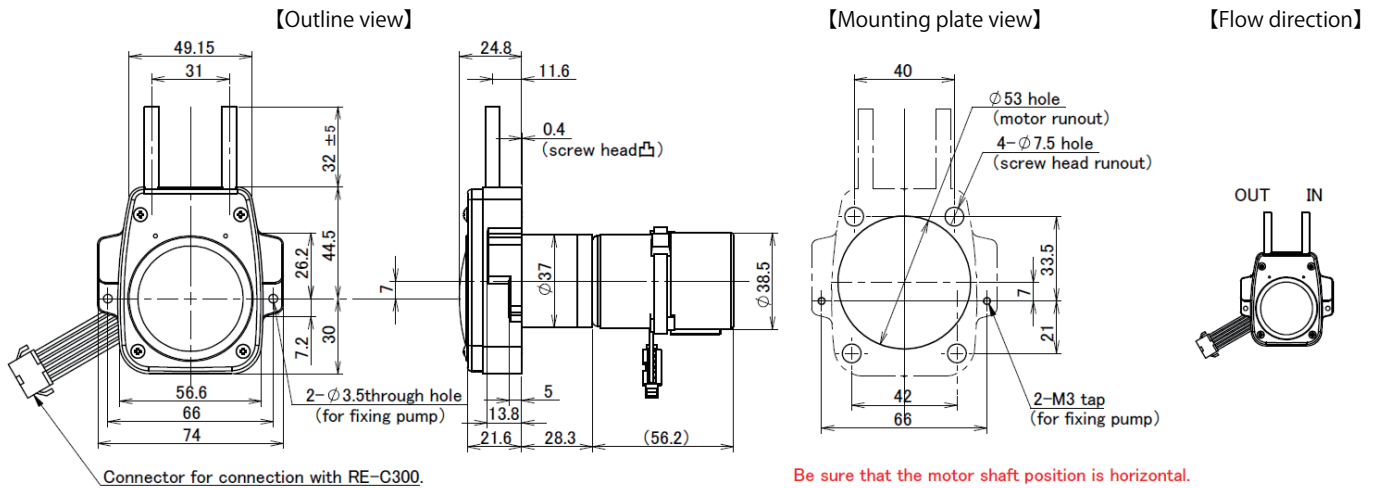

Model Lineup

Model Lineup	Voltage (DC/V)	Max. Flow rate (mL)	Tubing		System
			Type	IDxOD(mm)	RE-C300+ following pump
RE-C300-MC02S	24	25	Silicone	2.0 x 4.0	RP-MC02S-25Z-DC24VE
RE-C300-MC02F	24	25	PharMed BPT	2.0 x 4.0	RP-MC02F-25Z-DC24VE
RE-C300-MC02W	24	25	Transmaster TM-15	2.0 x 4.0	RP-MC02W-25Z-DC24VE

* PharMed BPT is product of Saint-Gobain SA. It is formerly described as PharMed in our brochure

* Transmaster TM-15 is product of Mitsubishi Co. Ltd., Japan.

Motor controller RE-C300



Install the dedicated software saved on the provided USB memory stick on your computer. By connecting the PC and dedicated motor controller “RE-C300” with the included USB cable, various operations of the pump become available. Various pump operation sequences can also be programmed.

Display panel of PC software (Example)

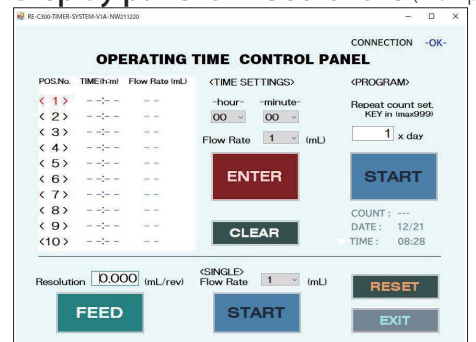

NB: For the Initial purchase, please select from above “System Models”. From the next purchase onward, the pump can be sold as a stand-alone unit.