

New !!

Ring Pump®

“Fixed Flow Rate” Pump System

RE-C300-HC Series

Features

- This is a metering pump system that combines an Aquatech’s ring pump using an encoder-equipped DC motor and its dedicated motor controller “RE-C300” to achieve metering by stopping the motor rotation at an exact integer multiple of one rotation.
- Pump head is replaceable and the docking of pump head can be done in a single action. No screw bolt needed
- Pump head can be sterilized.
 - Autoclave 121 degree C, 25 min. (all tubings except Transmaster TM-15)
 - Gamma rays 25kGy
- You can select tubing from 4 kinds of materials.

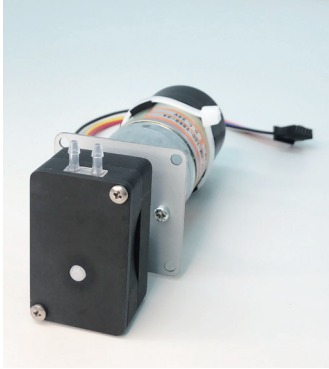

Main specifications

Flow rate	Max. 7mL / 0.2mL - Step
Tubing	Silicone / PharMed BPT Versilon F-5500-A / Transmaster TM-15
Motor/Power source	Encoder-equipped DC motor /24V
Weight (for reference)	Approx. 355g

Examples of application

Analytical instruments, medical devices, cell culturing experiments and many other usage where micro-fluidic control is needed.

【Outline view】

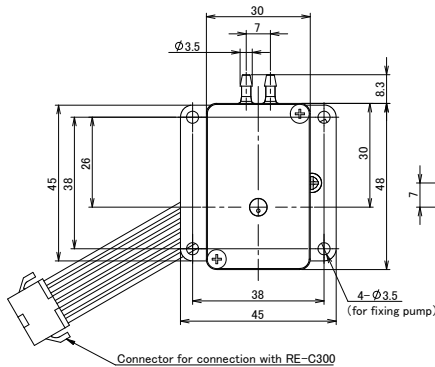

【Mounting plate view】

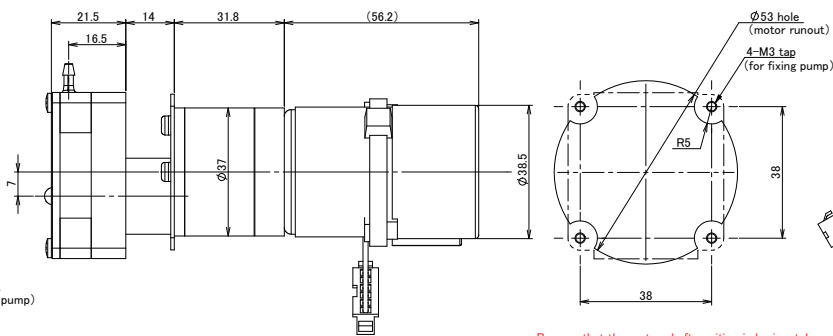

【Flow direction】

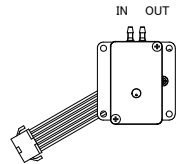

Model Lineup

System Models	Voltage (DC/V)	Max. Flow rate (mL)	Tubing		Replacement pumphead	System
			Type	ID x OD(mm)		RE-C300+ following pump
RE-C300-HC1.6S	24	7	Silicone	1.6 x 3.2	RK-H1.6S	RP-HC1.6S-7Z-DC24VE
RE-C300-HC1.6F	24	7	PharMed BPT	1.6 x 3.2	RK-H1.6F	RP-HC1.6F-7Z-DC24VE
RE-C300-HC1.6R	24	7	Versilon F-5500-A	1.6 x 3.2	RK-H1.6R	RP-HC1.6R-7Z-DC24VE
RE-C300-HC1.6W	24	7	Transmaster TM-15	1.6 x 3.2	RK-H1.6W	RP-HC1.6W-7Z-DC24VE

* PharMed BPT and Versilon F-5500-A are products of Saint-Gobain SA. They were formerly described as PharMed and Fluran in our brochure.

* Transmaster TM-15 is product of Mitsubishi Co. Ltd., Japan.

Motor controller RE-C300



Install the dedicated software saved on the provided USB memory stick on your computer.
By connecting the PC and dedicated motor controller “RE-C300” with the included USB cable, various operations of the pump become available.
Various pump operation sequences can also be programmed.

Display panel of PC software (Example)

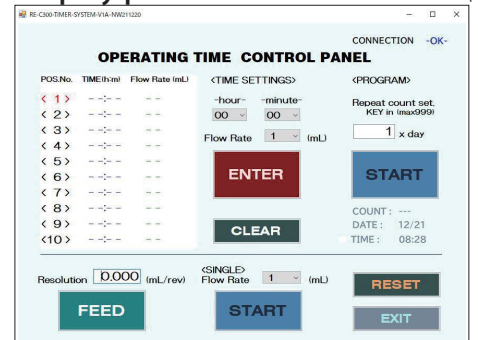

NB: For the Initial purchase, please select from above “System Models”. From the next purchase onward, the pump can be sold as a stand-alone unit.